

Cellular Biophysics & Modeling

Lecture 10

The Morris-Lecar model of barnacle muscle fiber

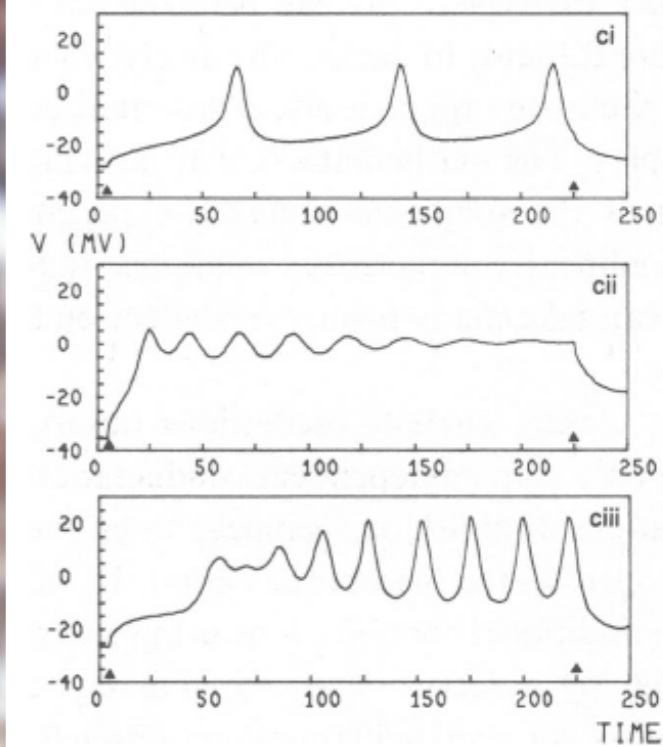
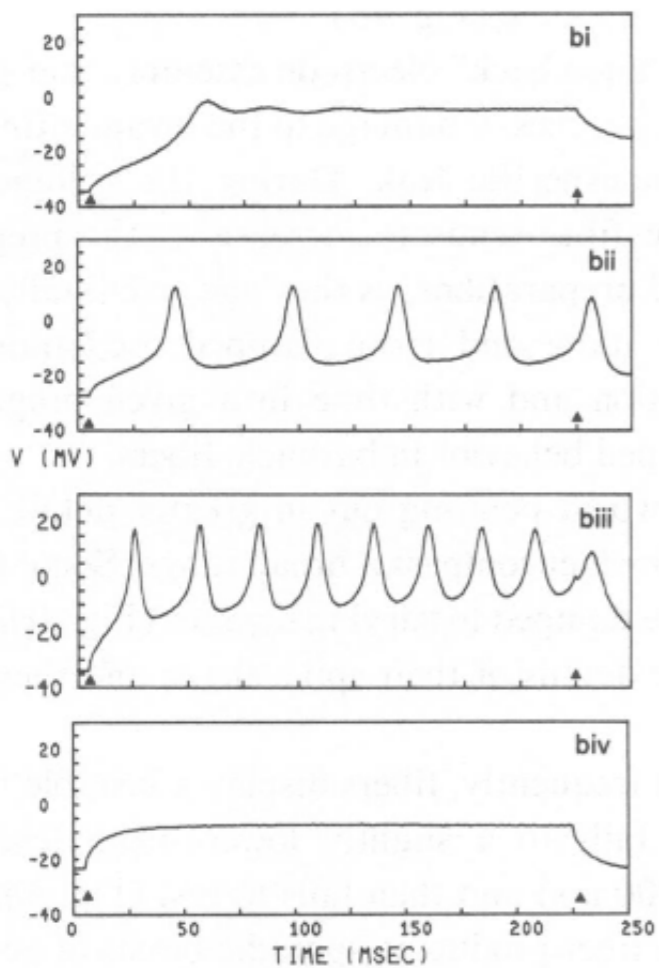

muscle fiber recordings

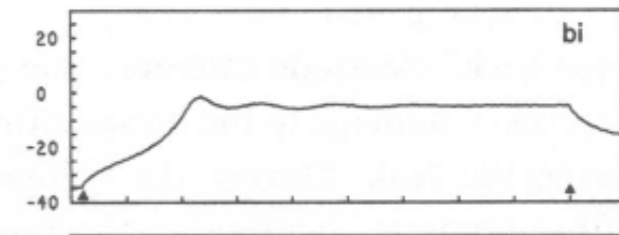
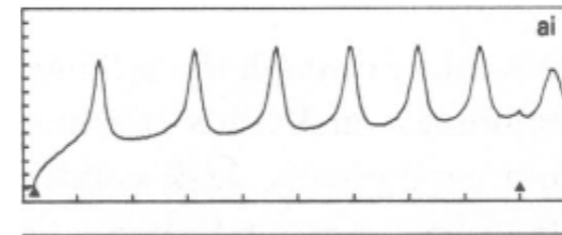
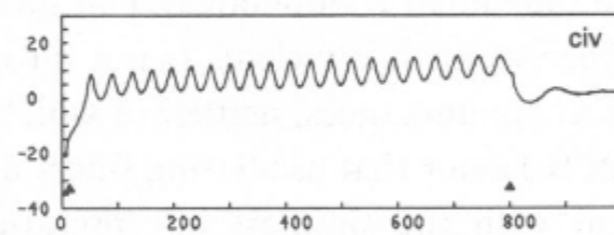
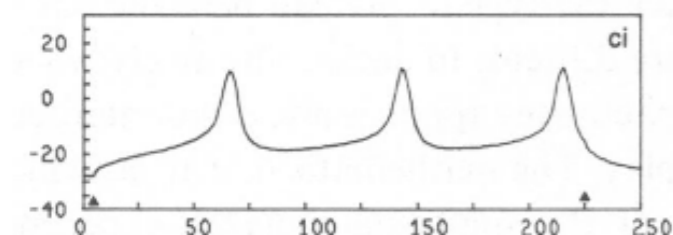

VOLTAGE OSCILLATIONS IN THE BARNACLE GIANT MUSCLE FIBER

CATHERINE MORRIS AND HAROLD LECAR, *Laboratory of Biophysics, National Institute of Neurological and Communicative Disorders and Stroke, National Institutes of Health, Bethesda, Maryland 20205*

ABSTRACT Barnacle muscle fibers subjected to constant current stimulation produce a variety of types of oscillatory behavior when the internal medium contains the Ca^{++} chelator EGTA. Oscillations are abolished if Ca^{++} is removed from the external medium, or if the K^+ conductance is blocked. Available voltage-clamp data indicate that the cell's active conductance systems are exceptionally simple. Given the complexity of barnacle fiber voltage behavior, this seems paradoxical. This paper presents an analysis of the possible modes of behavior available to a system of two noninactivating conductance mechanisms, and indicates a good correspondence to the types of behavior exhibited by barnacle fiber. The differential equations of a simple equivalent circuit for the fiber are dealt with by means of some of the mathematical techniques of nonlinear mechanics.

electrical recordings from depressor scutorum rostralis muscle fibers

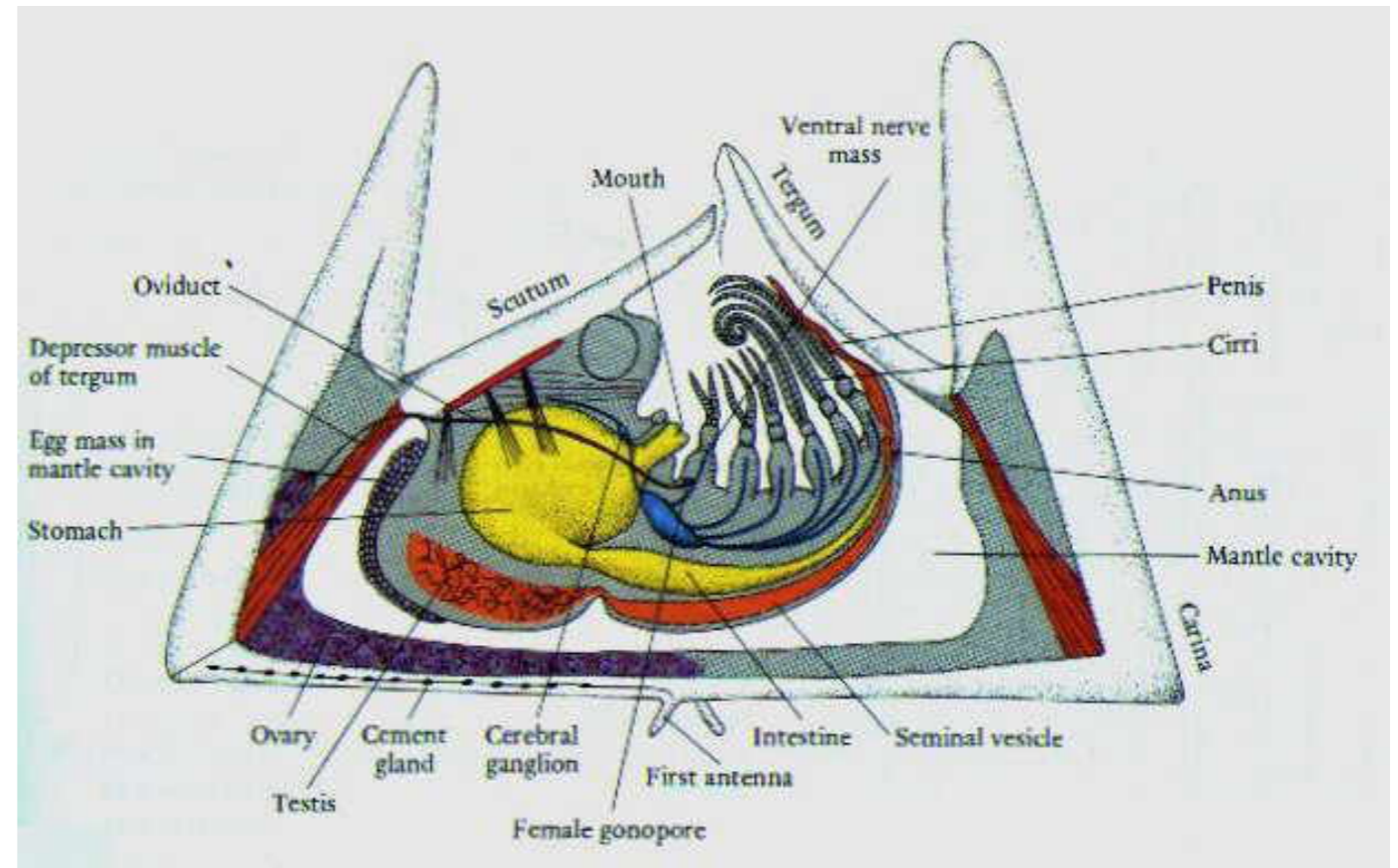

Large specimens of the barnacle *Balanus nubilus* were sawed into lateral halves, and the *depressor scutorum rostralis* muscles were carefully exposed. Individual fibers were dissected, the incision starting from the tendon. The other end of the muscle was cut close to its attachment on the shell and ligatured. Isolated fibers were either used immediately or kept for up to 30 min in standard artificial seawater before use. Experiments were carried out at room temperature.

representative voltage oscillations during electrical recordings from barnacle muscle fiber

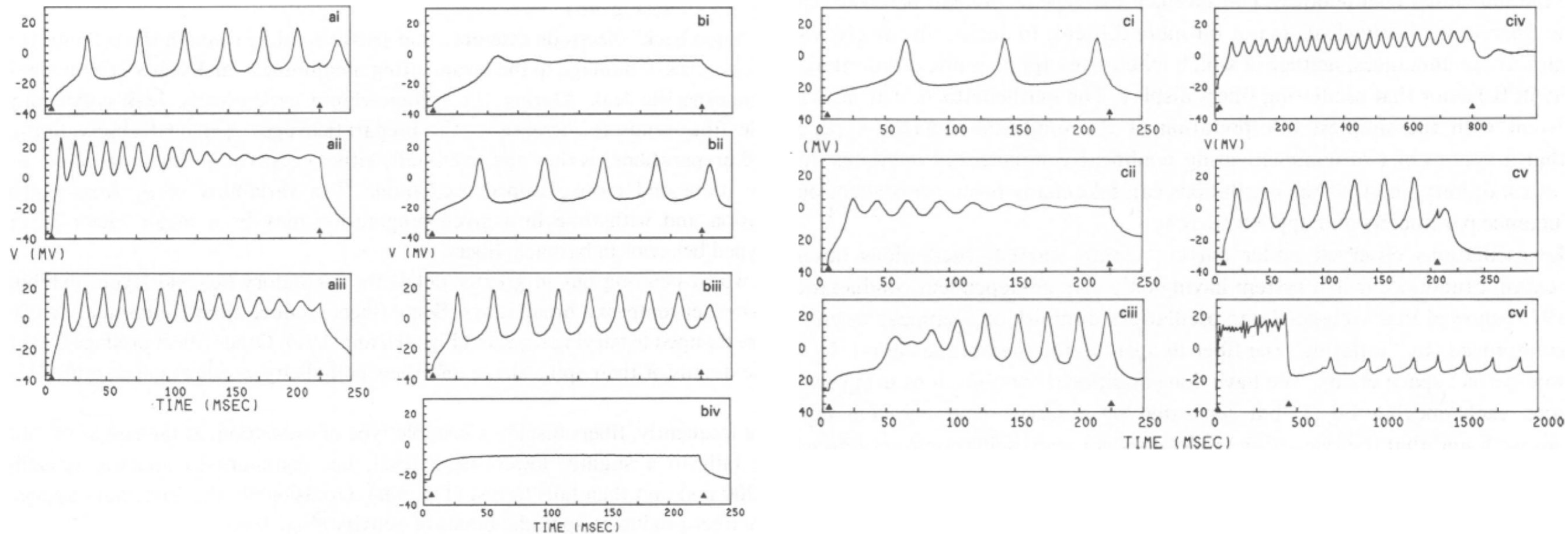

FIGURE 4 Voltage oscillations in fibers with Ca^{++} and K^{+} conductances. External saline: either ASW (*ai, aii, aiii, bi, biii, cii*), Ca^{++} -free ASW (*biv*), or, in all others, high Ca^{++} ASW. Internal saline: K^{+} perfusate. Voltage, mV; time, ms. (*a*) Voltage responses of a fiber to varying current stimulus. Current from top to bottom: 180, 540, and 900 μA . (*b*) Effect of varying $[\text{Ca}^{++}]_o$. Current stimulus, 240 μA . *i, ii,* and *iii, iv* are from two different fibers. In *i* and *ii*, $[\text{Ca}^{++}]_o$ is increased from 10 mM (*i*) to 100 mM (*ii*). In *iii* and *iv* it is decreased from 10 mM (*i*) to 0 mM (*iv*). The contrast between *i* and *iii* also illustrates how variable the oscillatory response can be from fiber to fiber. Trace *iv* illustrates the *RC* response of the fiber in 0 mM Ca^{++} . (*c*) Variety of oscillatory characteristics. Current stimuli are 180, 600, 180, 360, 960, and 600 μA from *i* through *vi*.



The full Morris-Lecar model of barnacle muscle fiber

(Cathy Morris and Harold Lecar, 1981)

$$C \frac{dV}{dt} = I_{app} - g_L (V - E_L) - g_{Ca} m (V - E_{Ca}) - g_K w (V - E_K)$$

$$\frac{dm}{dt} = - \frac{m - m_\infty(V)}{\tau_m(V)}$$

$$\frac{dw}{dt} = - \frac{w - w_\infty(V)}{\tau_w(V)}$$

One leakage current and two voltage-gated currents

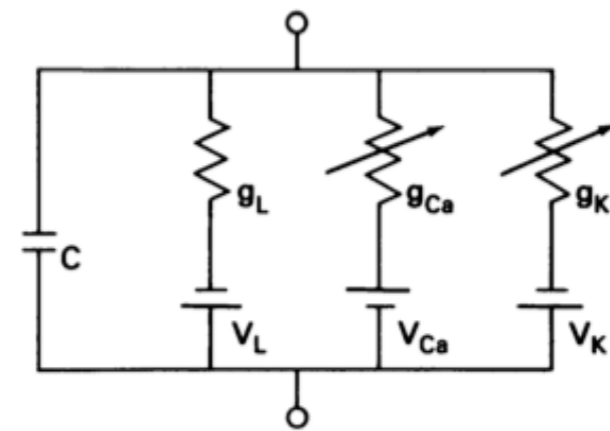

FIGURE 1 Equivalent circuit for a patch of space-clamped barnacle sarcolemma.

Such models reproduce membrane excitability, oscillations, bursting, etc., but how can we analyze and understand them?

Calcium current activates fast (1 ms)

This is faster than the potassium current activates (10s of ms) and faster than membrane time constant ($\tau = C/g = 10$ ms)

So assume activation of calcium current is “instantaneous” function of voltage in order to simplify membrane model

This means $m(t) = m_{\infty}(V(t))$ — and this allows us to eliminate an equation. Now there are only two!

The reduced Morris-Lecar model

$$C \frac{dV}{dt} = I_{app} - g_L (V - E_L) - g_{Ca} m_\infty(V) (V - E_{Ca}) - g_K w (V - E_K)$$

$$\frac{dw}{dt} = -\phi \frac{w - w_\infty(V)}{\tau_w(V)}$$

instantaneously equilibrating
activation gating variable for
the inward Ca^{2+} current

slow activation gating
variable for the
outward K^+ current

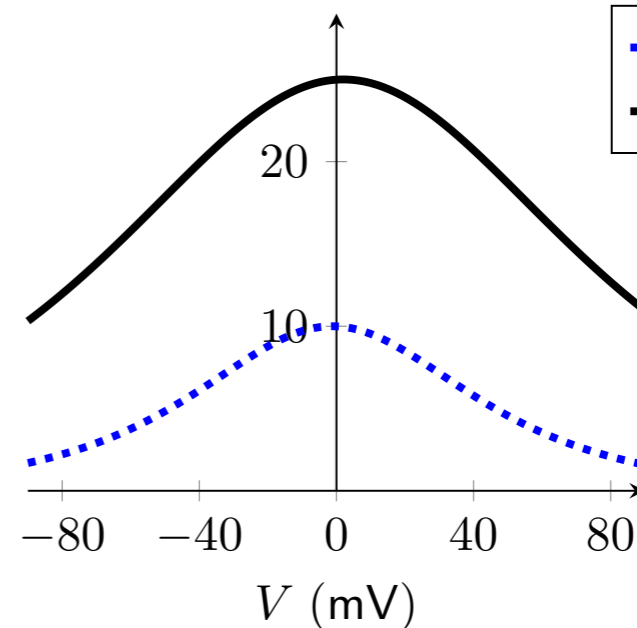
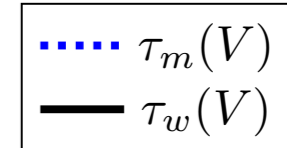
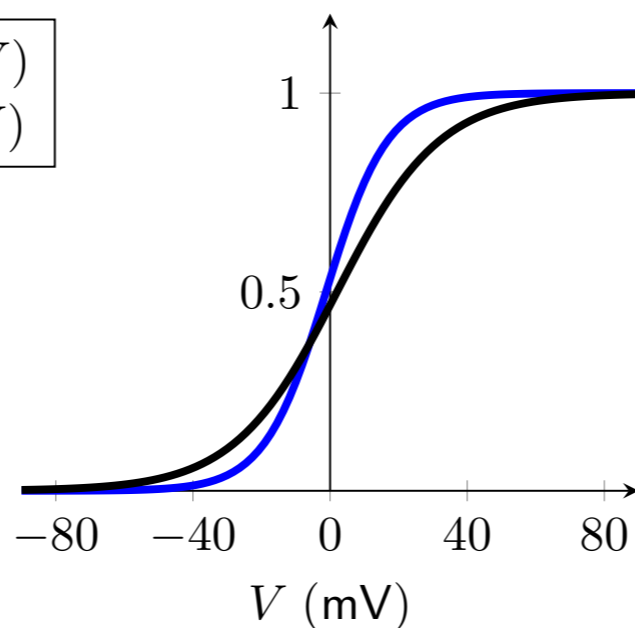
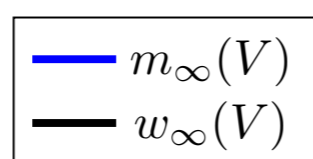

Morris-Lecar Simulator

<http://www.compadre.org/osp/document/ServeFile.cfm?ID=12417&DocID=3123#Doc3123>

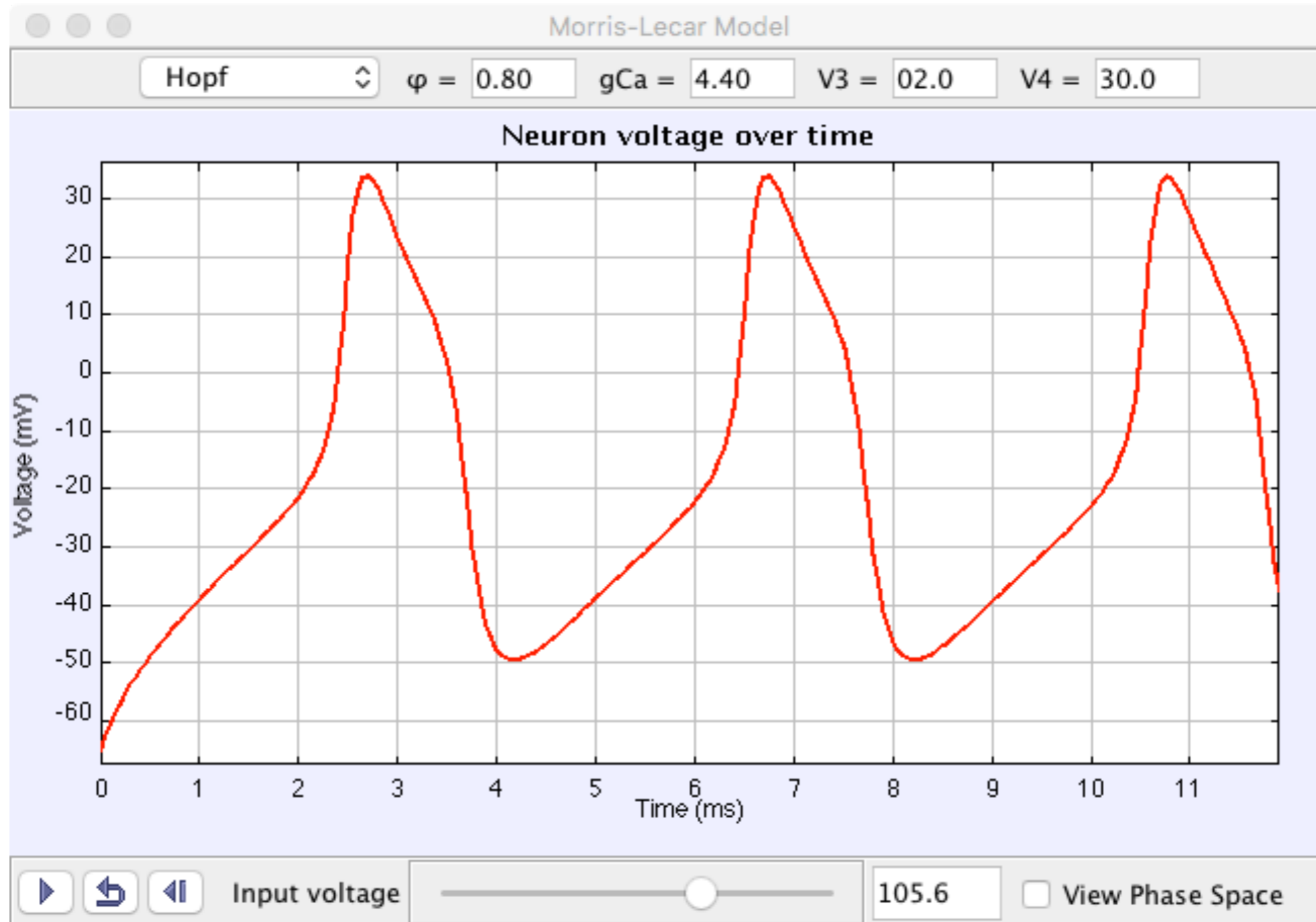

The Morris-Lecar model - membrane oscillations

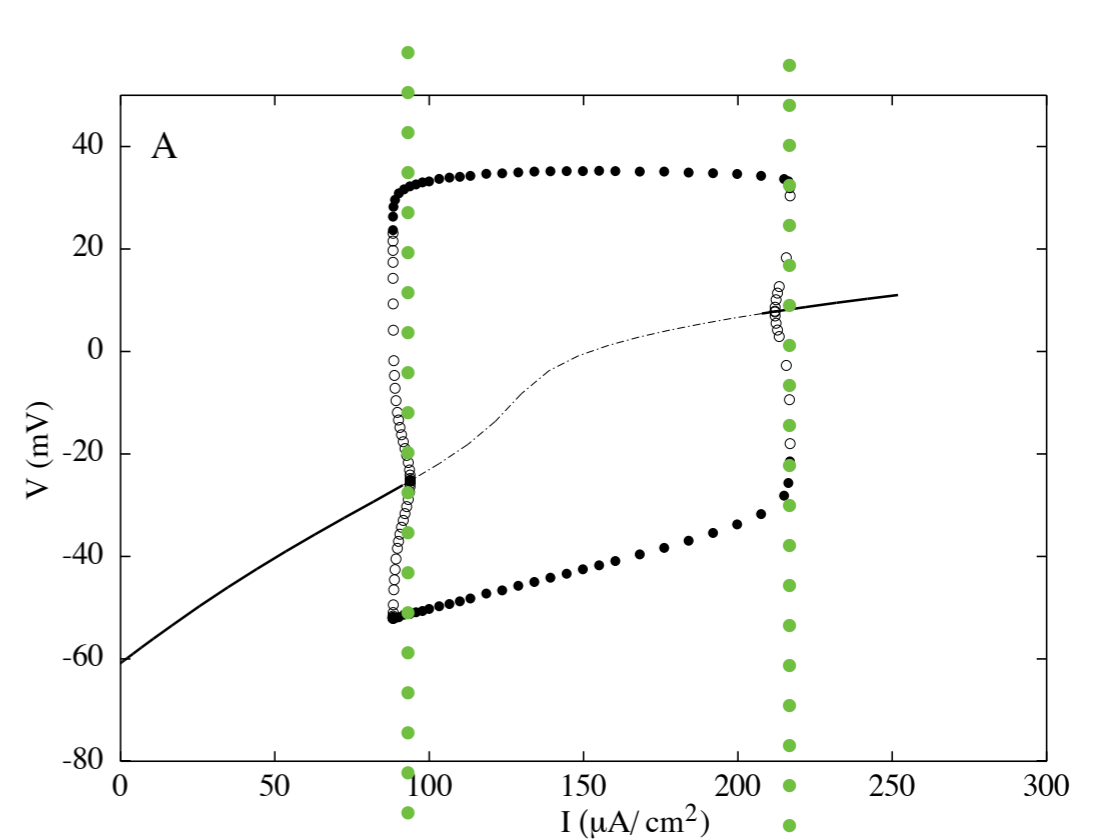
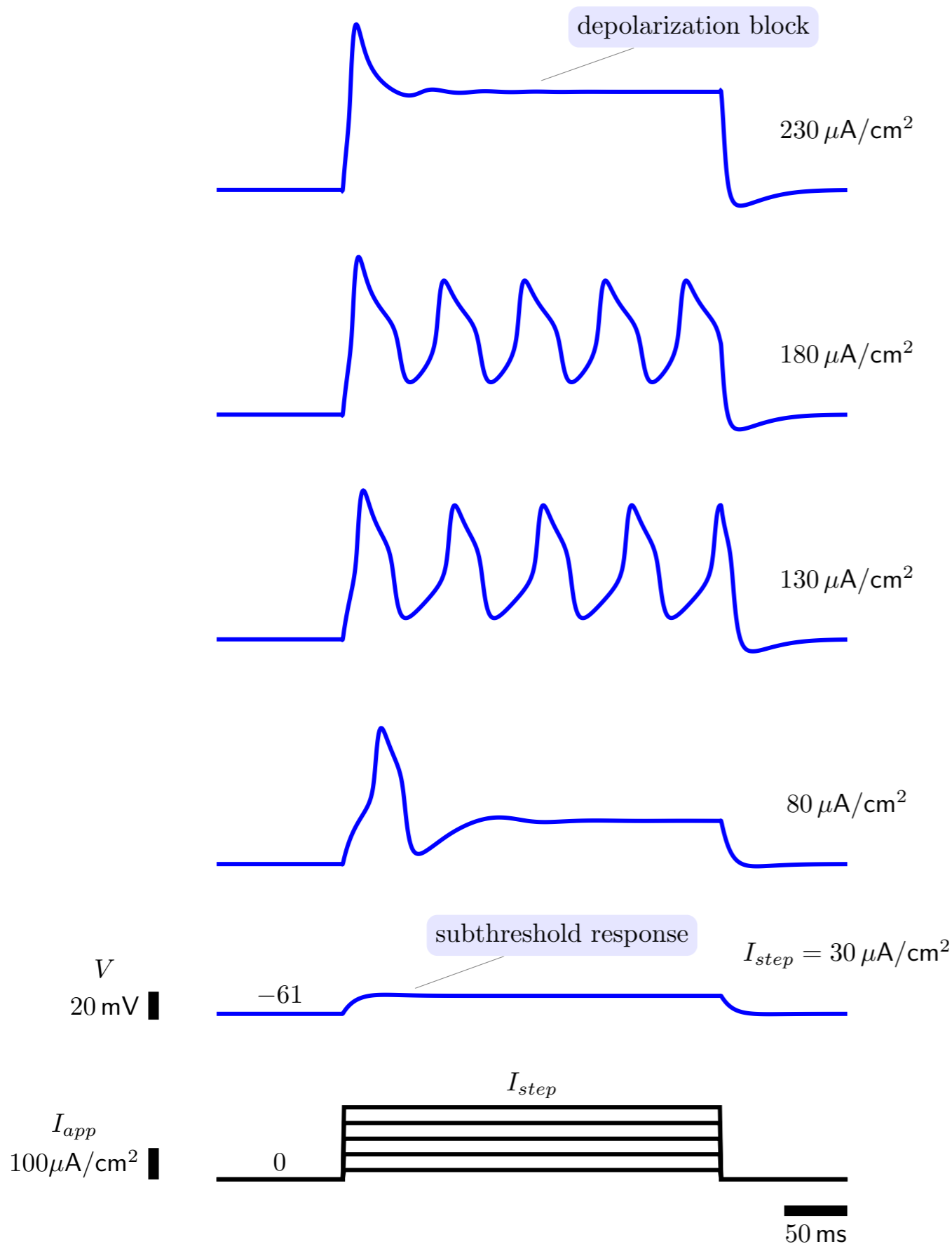

↑
freq

7 Hz

0

Note: as I_{app} increases through critical value, these oscillations begin with **nonzero frequency**
"type 2 oscillations"

The Morris-Lecar model - bifurcation diagram

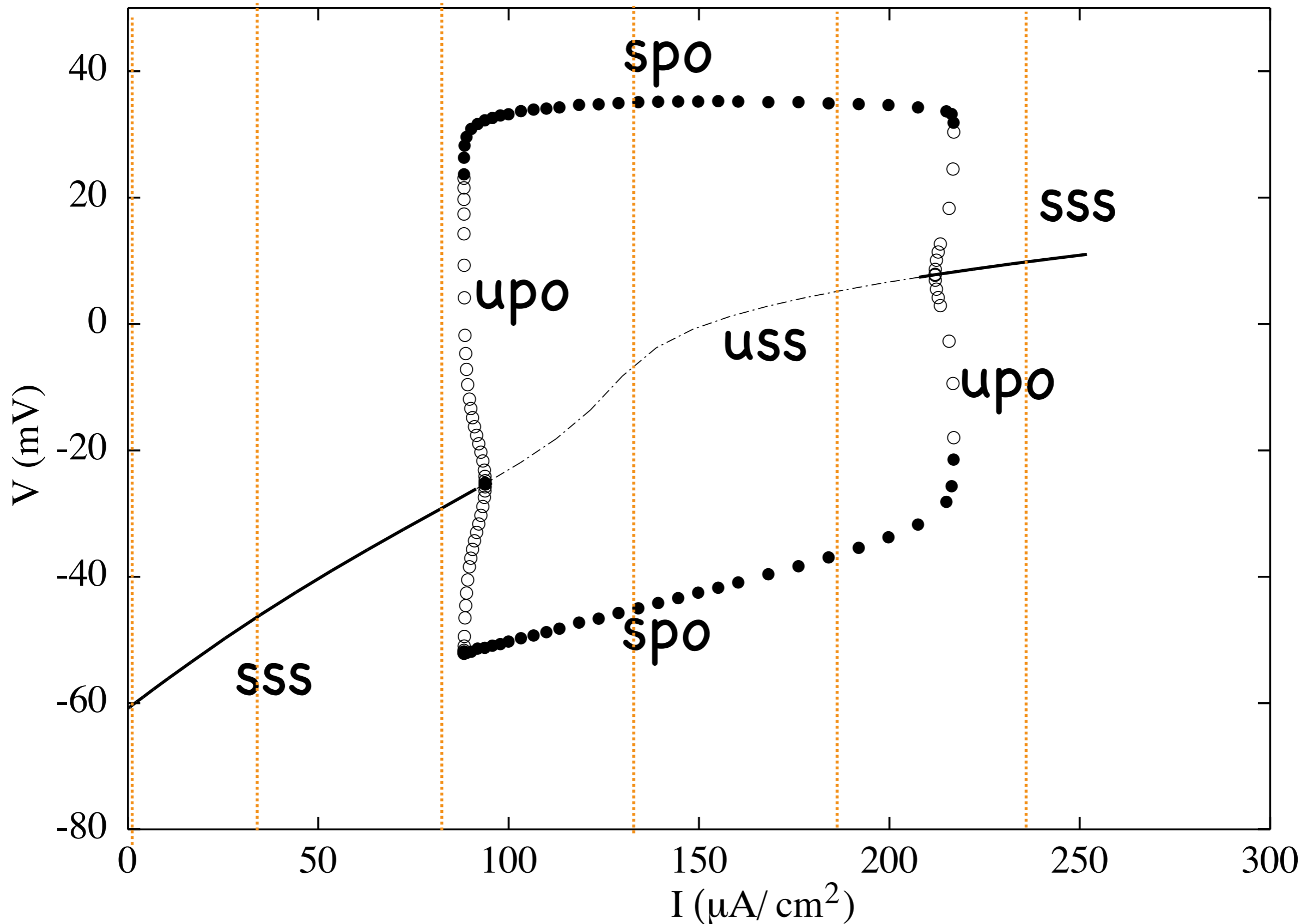

The Morris-Lecar model - bifurcation diagram

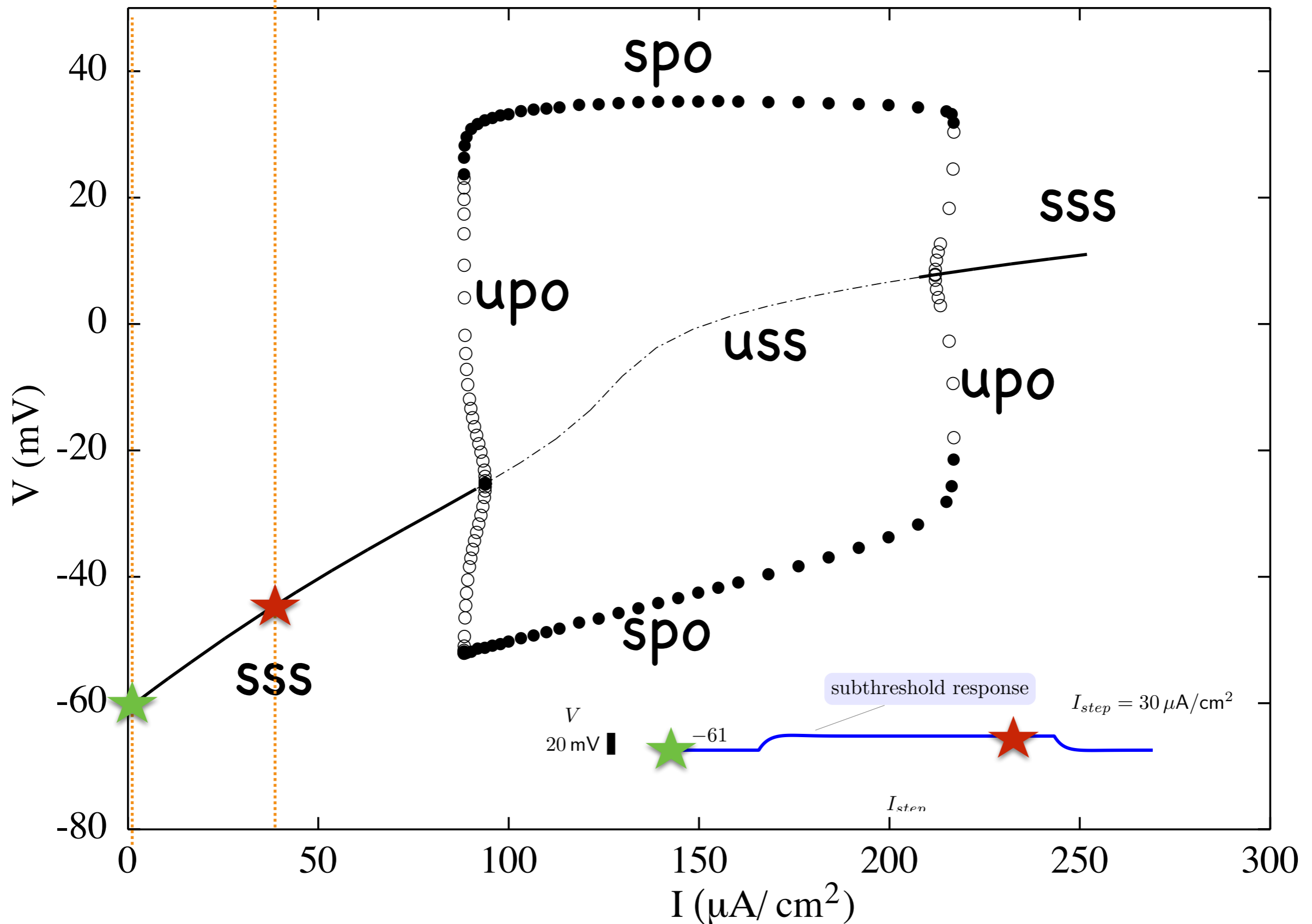

The Morris-Lecar model - bifurcation diagram

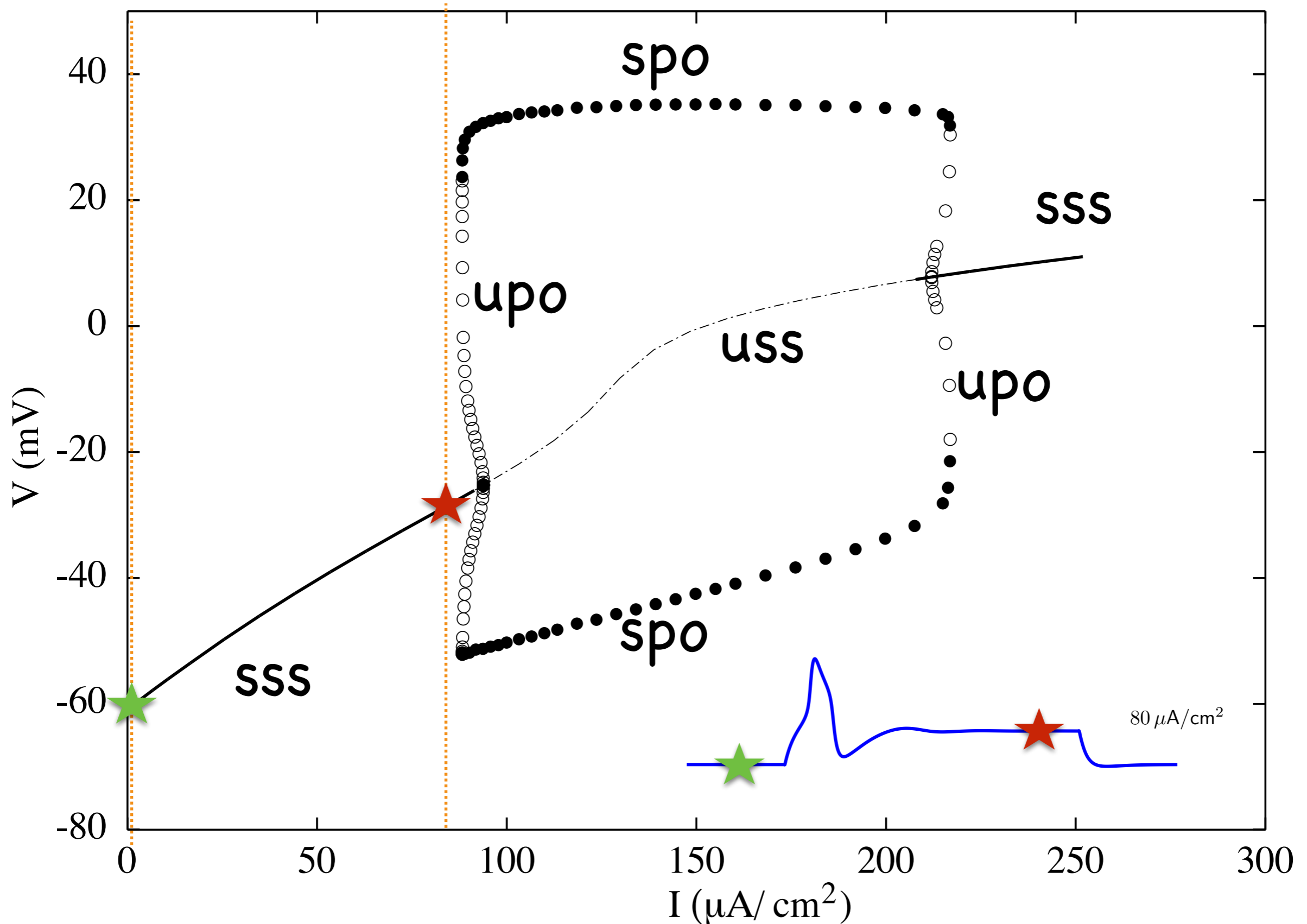

The Morris-Lecar model - bifurcation diagram

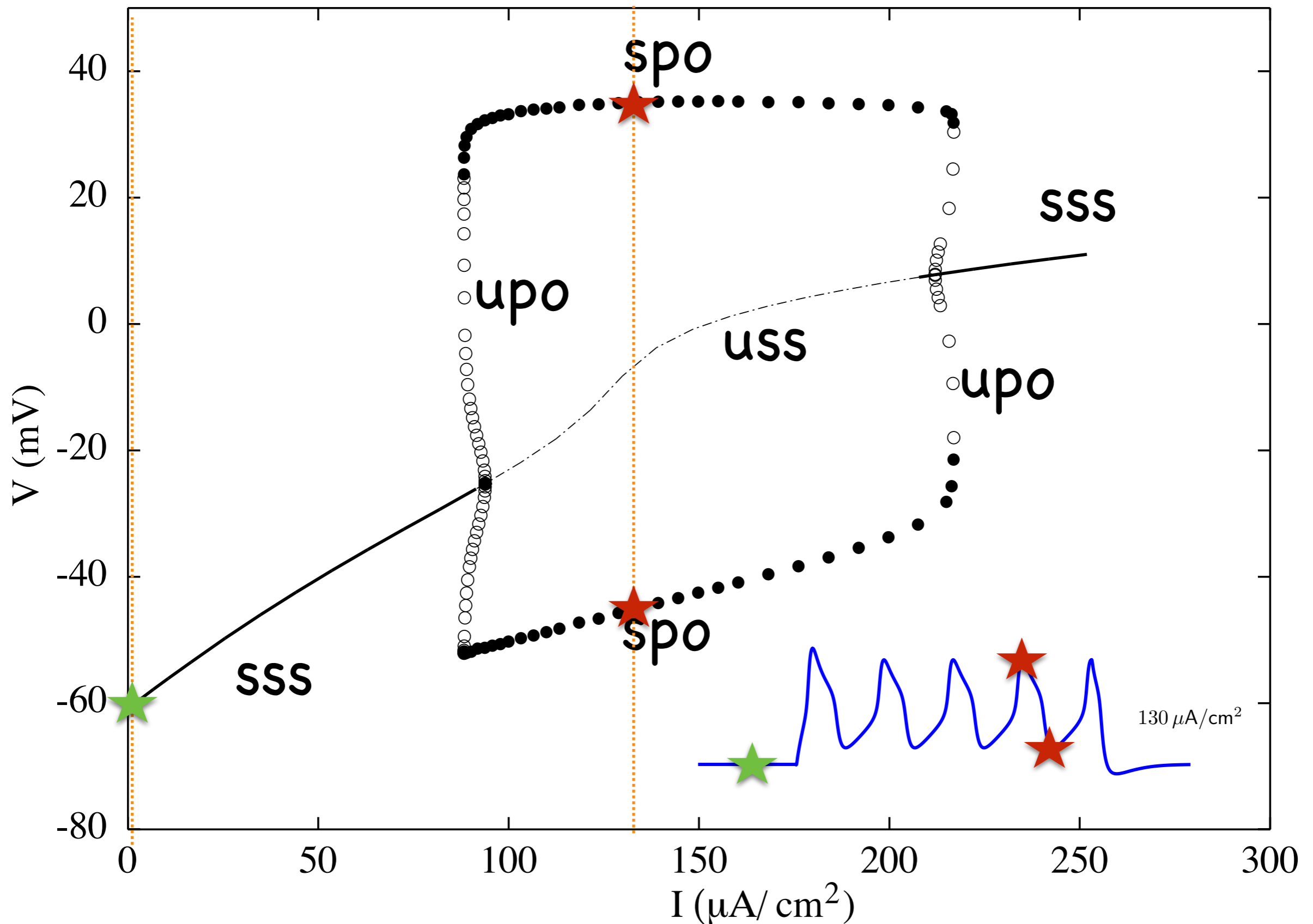

The Morris-Lecar model - bifurcation diagram

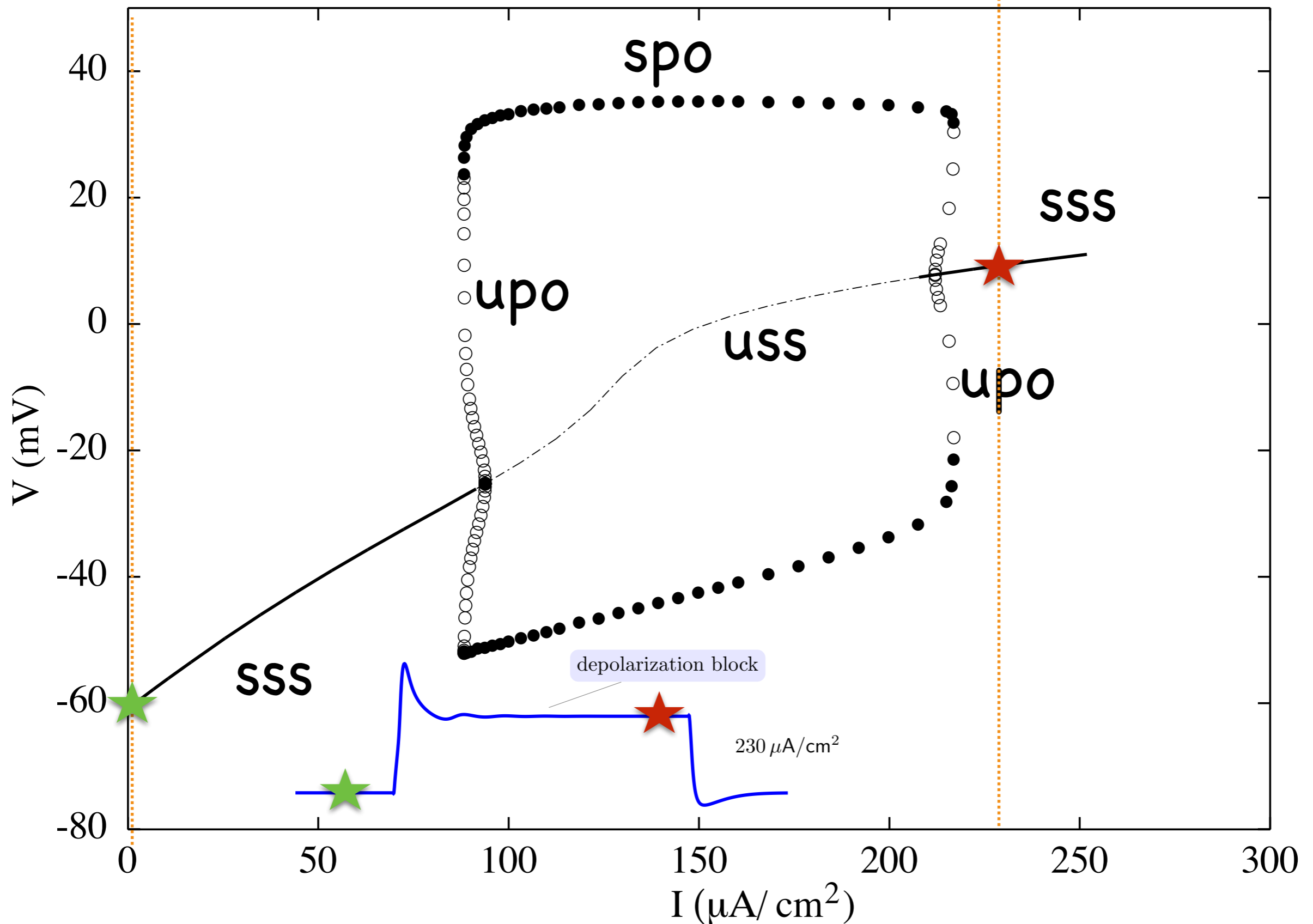

bifurcation diagram shows min and max of periodic solution

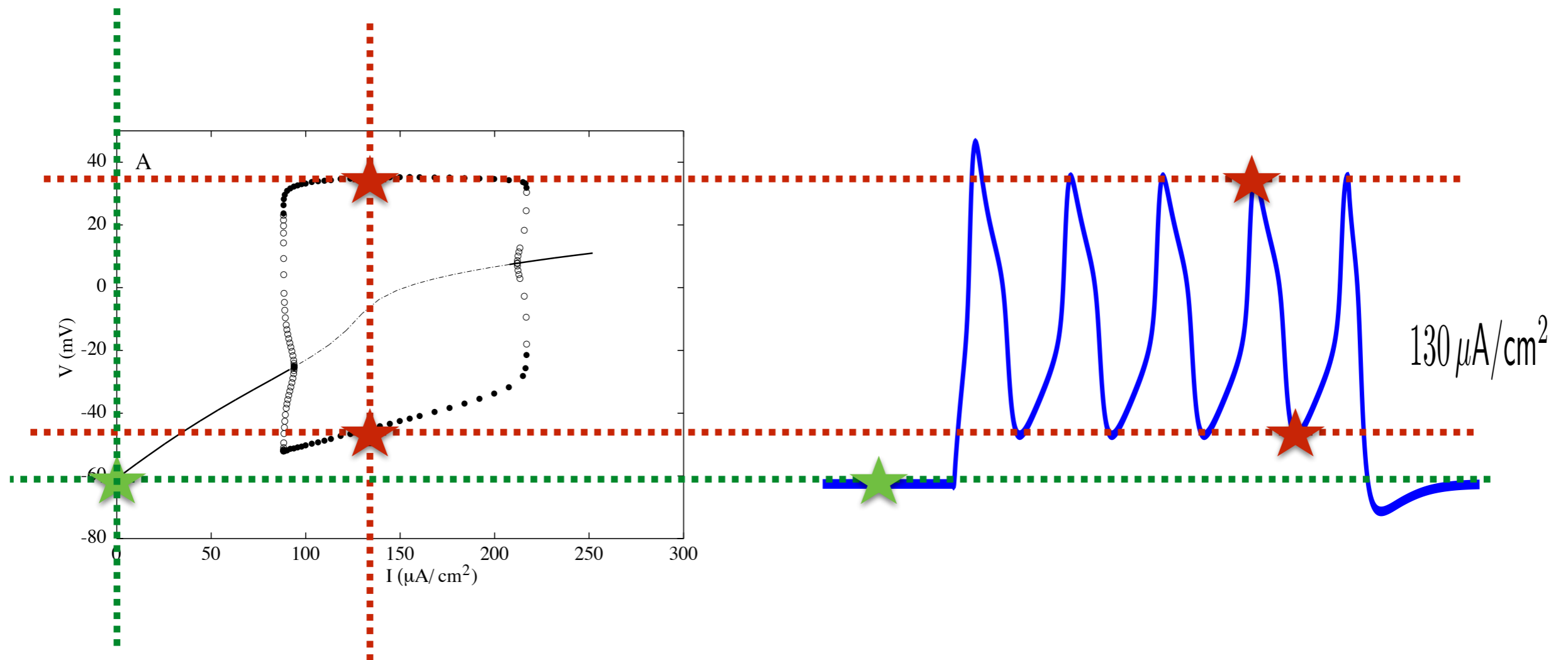

The Morris-Lecar model - oscillation frequency

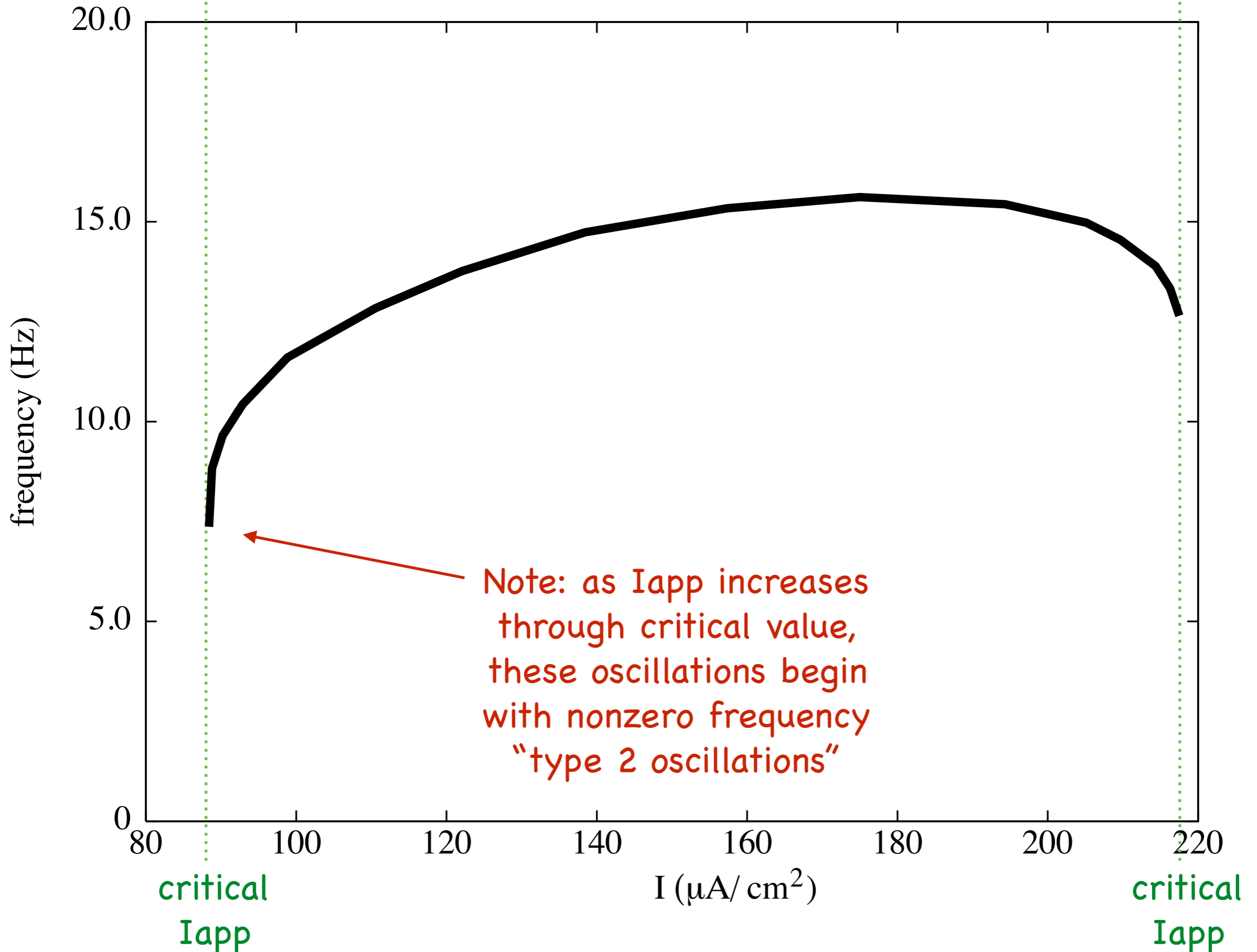

similar phenomenon in squid giant axon

Hodgkin A.L. (1948) The local electric changes associated with repetitive action in a non-medulated axon. *Journal of Physiology* 107:165-181.

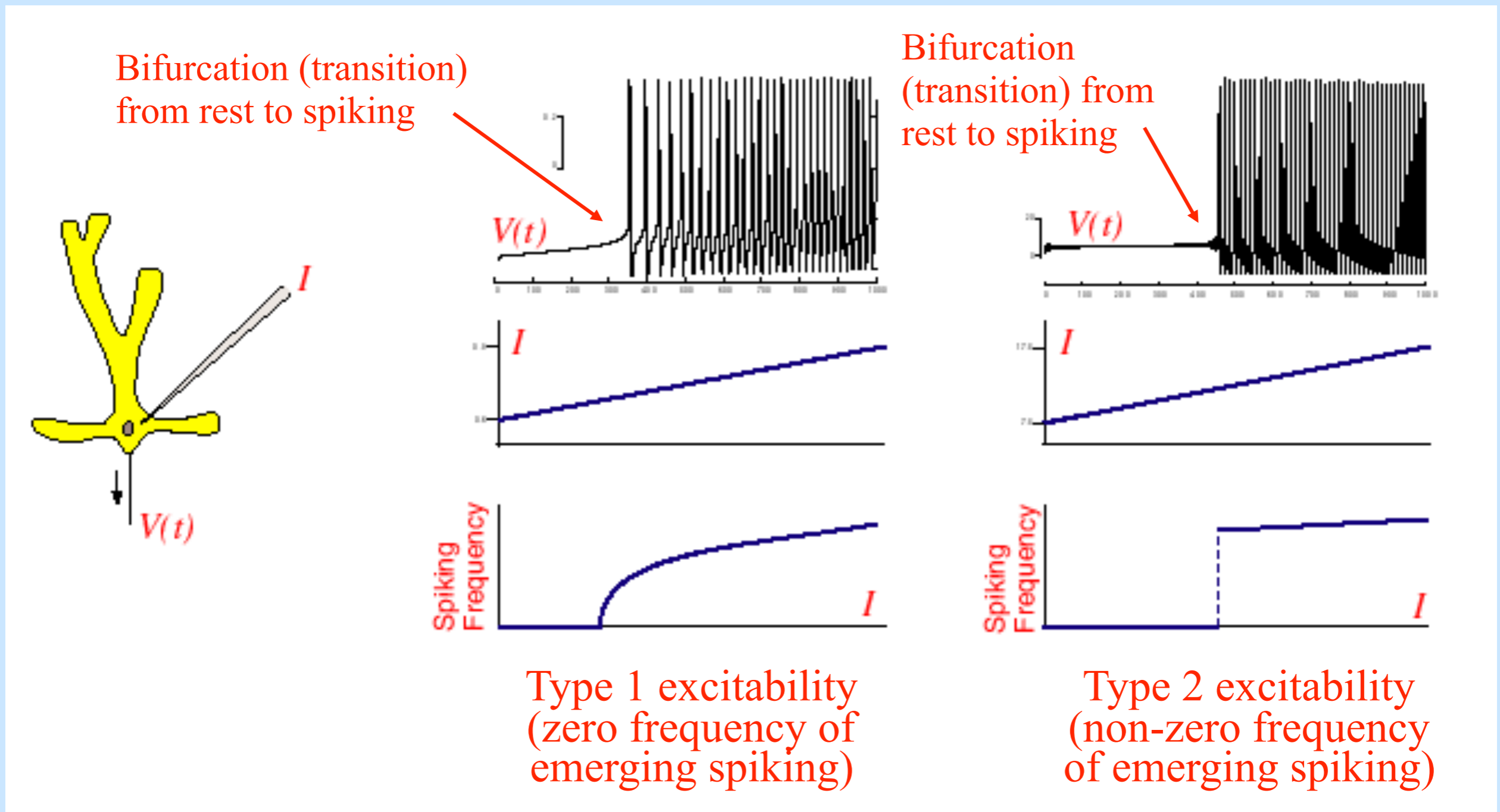

The Morris-Lecar model - membrane excitability

graded action potentials
(size depends on initial voltage)

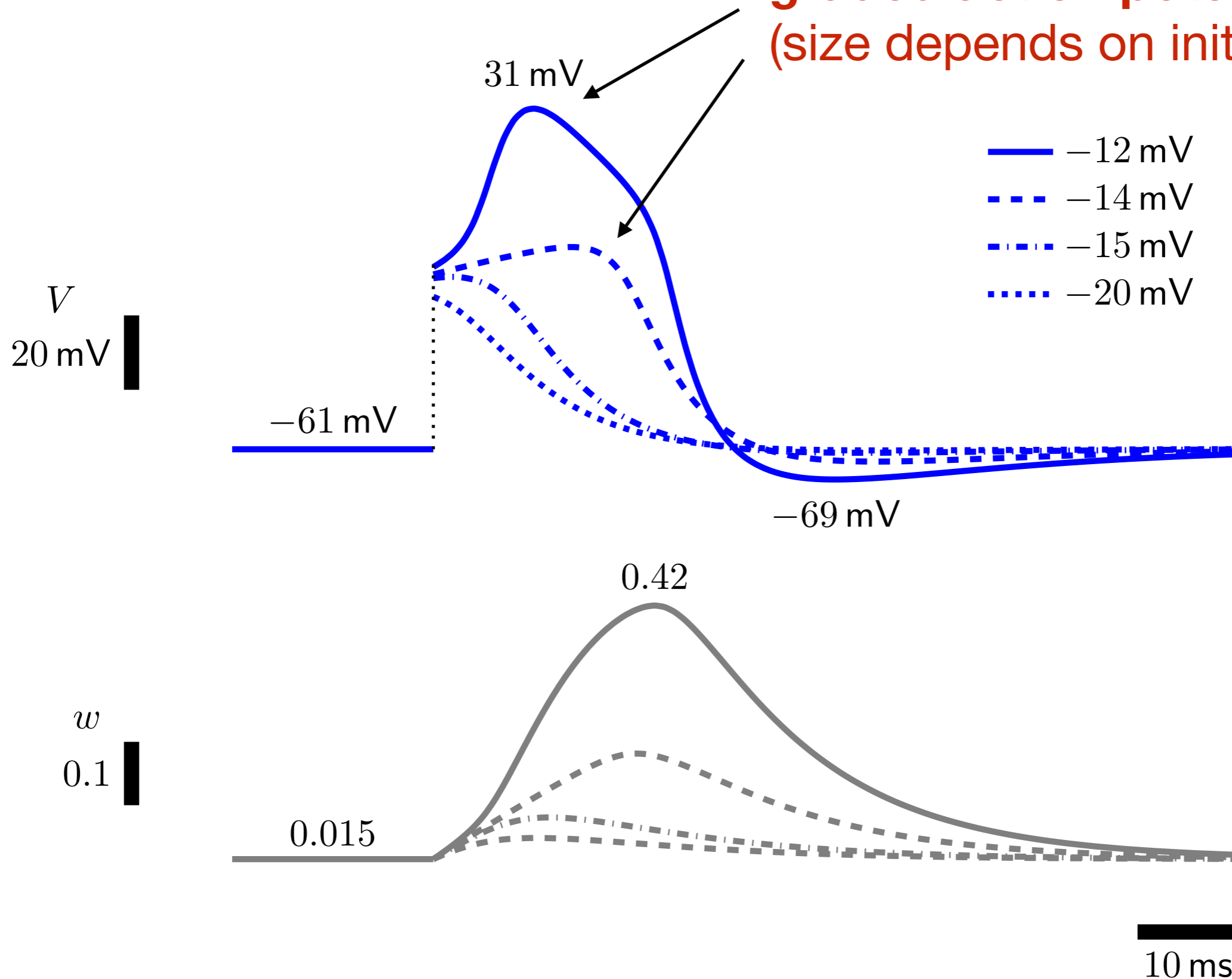

nulclines & direction field & solutions

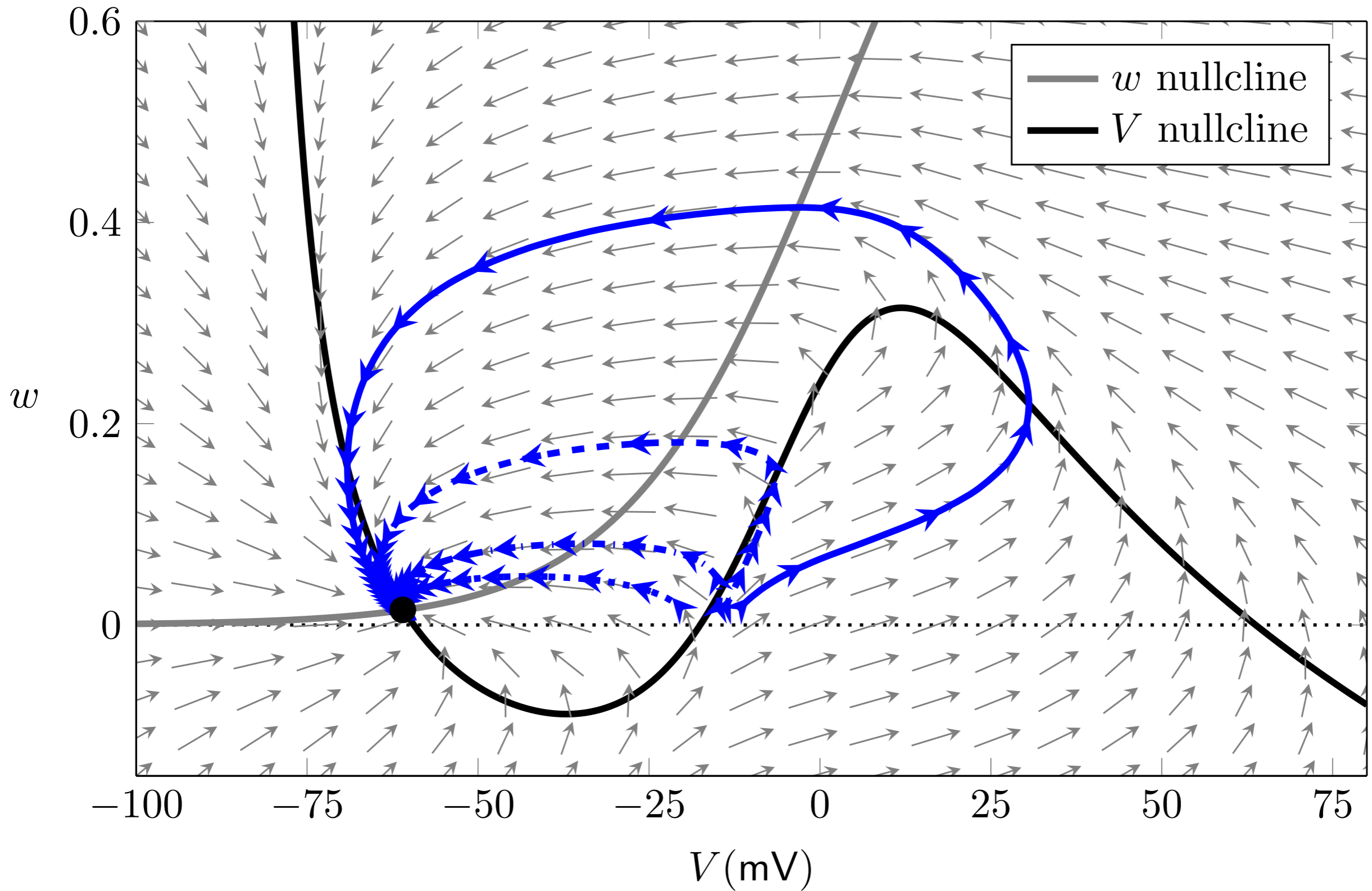

Morris-Lecar model - phase plane w/ nullclines

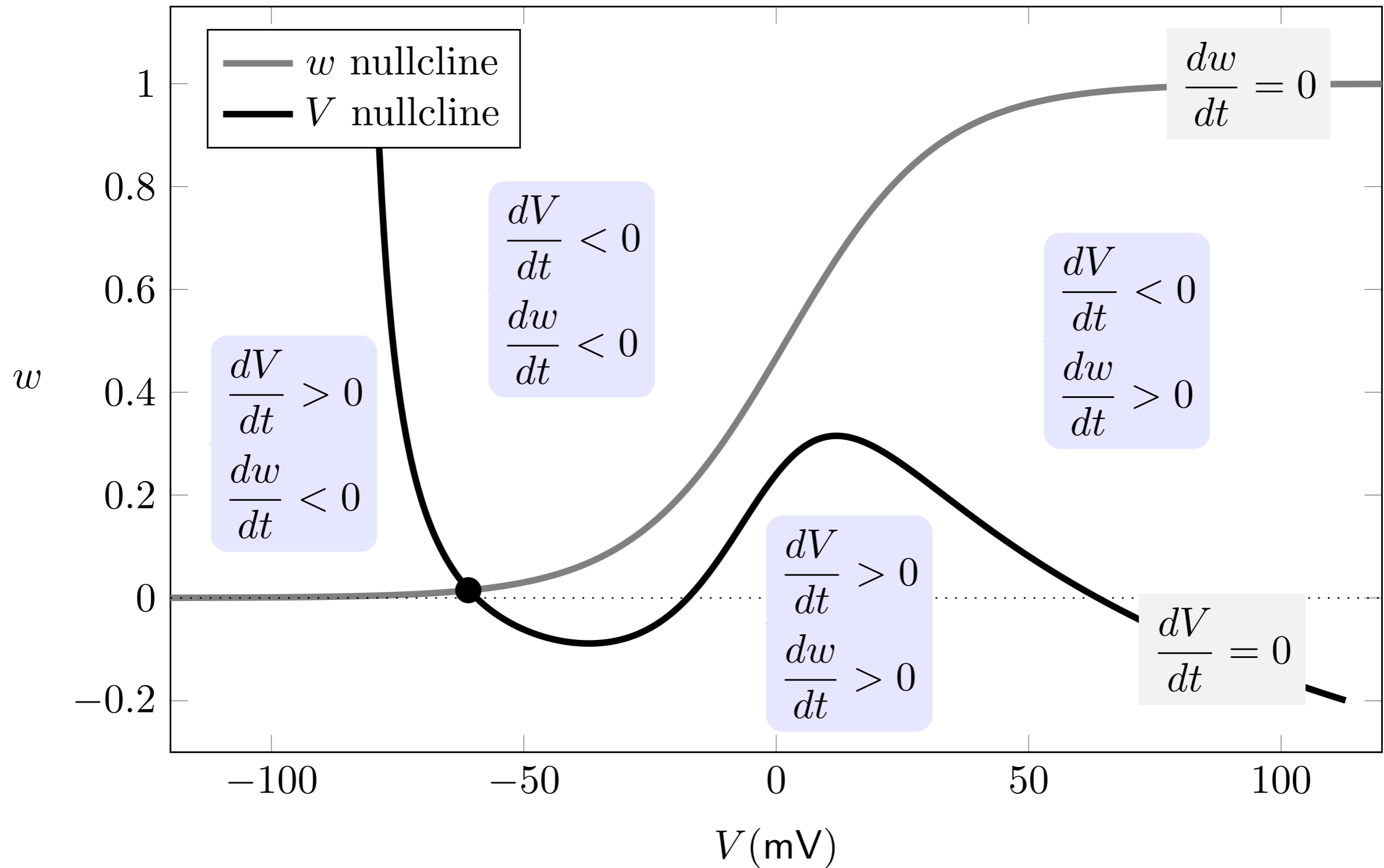

membrane excitability when potassium channel gating is very slow (Φ is small so τ_w is large)

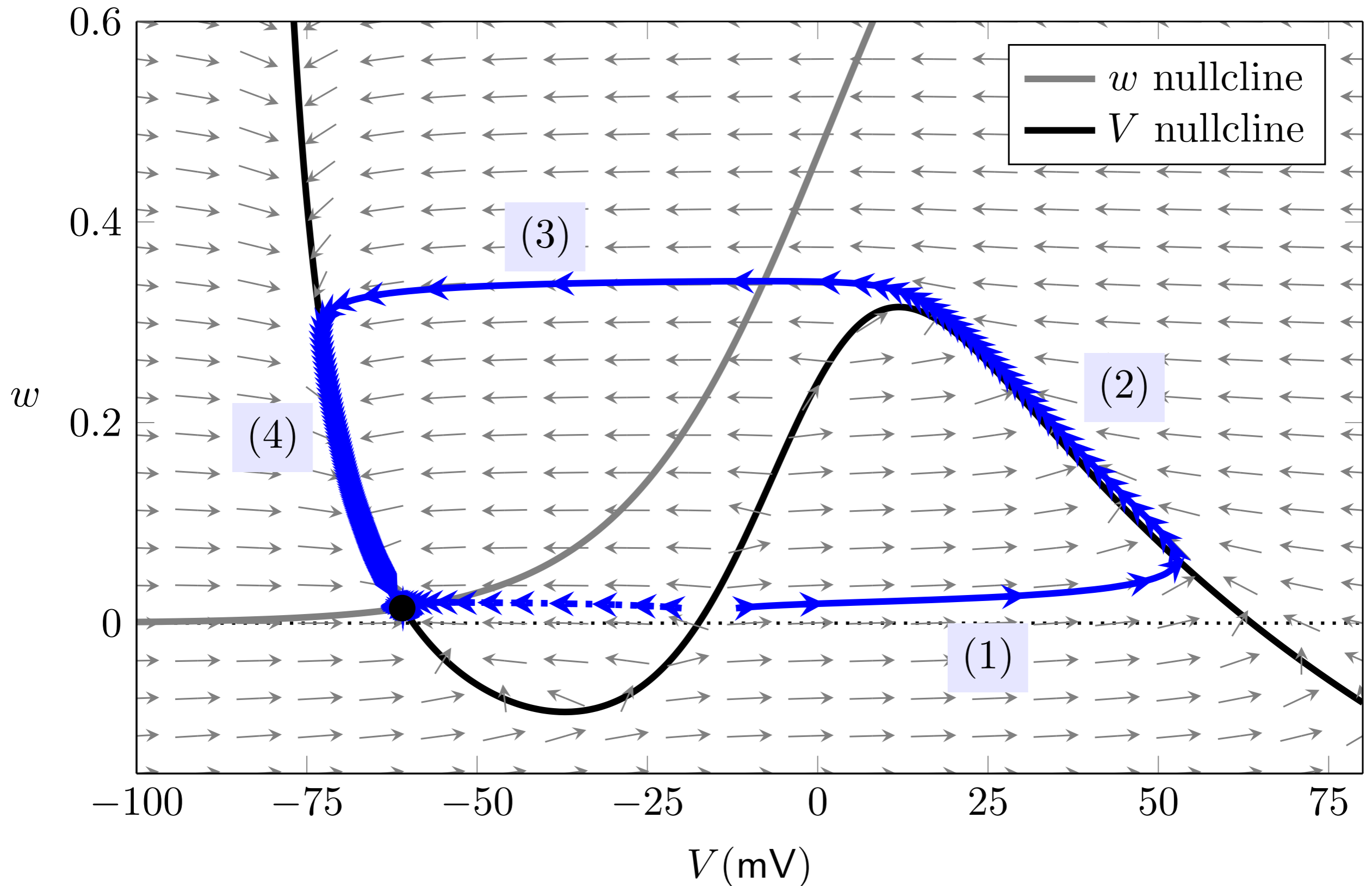

membrane excitability when potassium channel gating is very slow (Φ is small so τ_w is large)

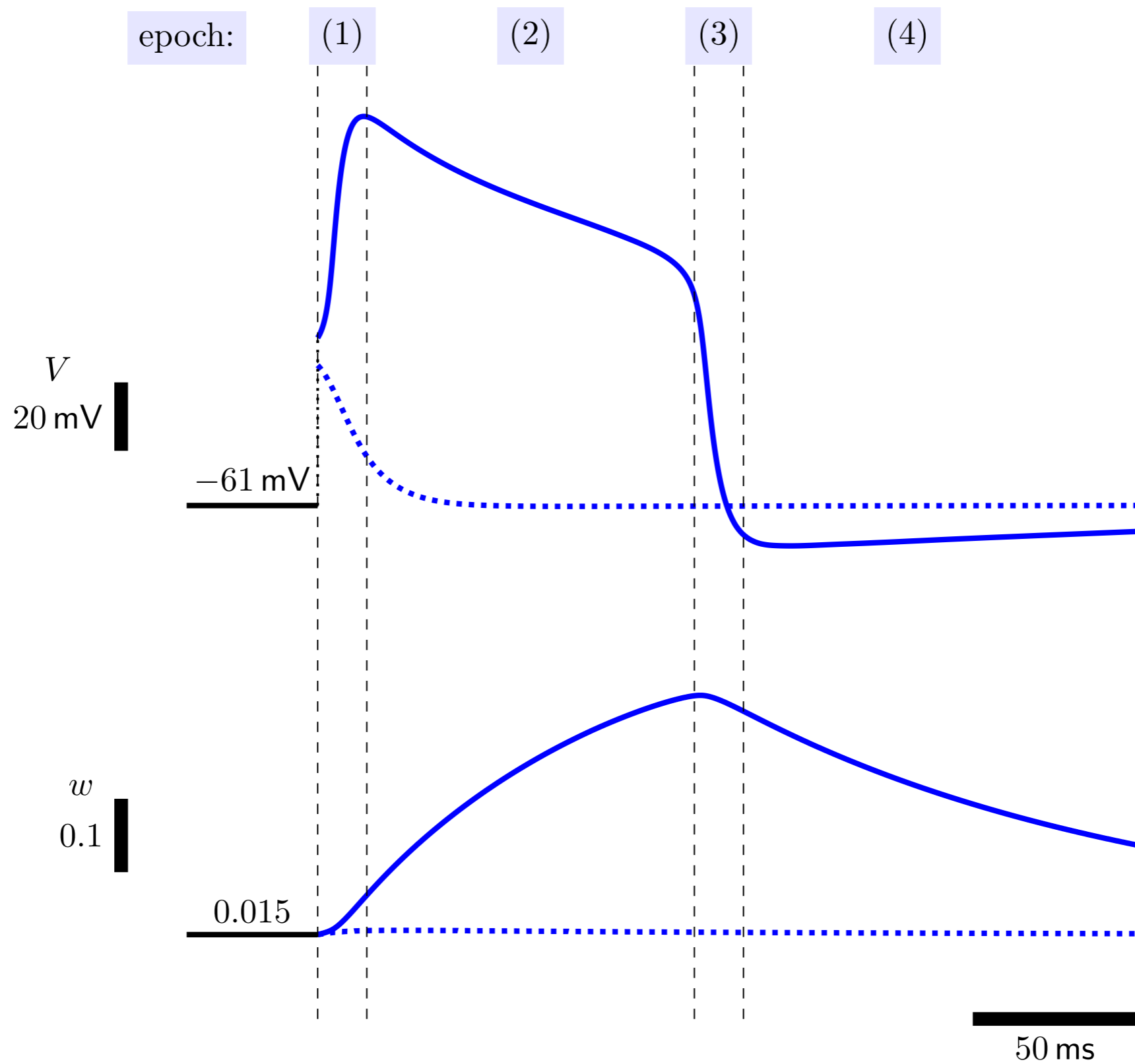

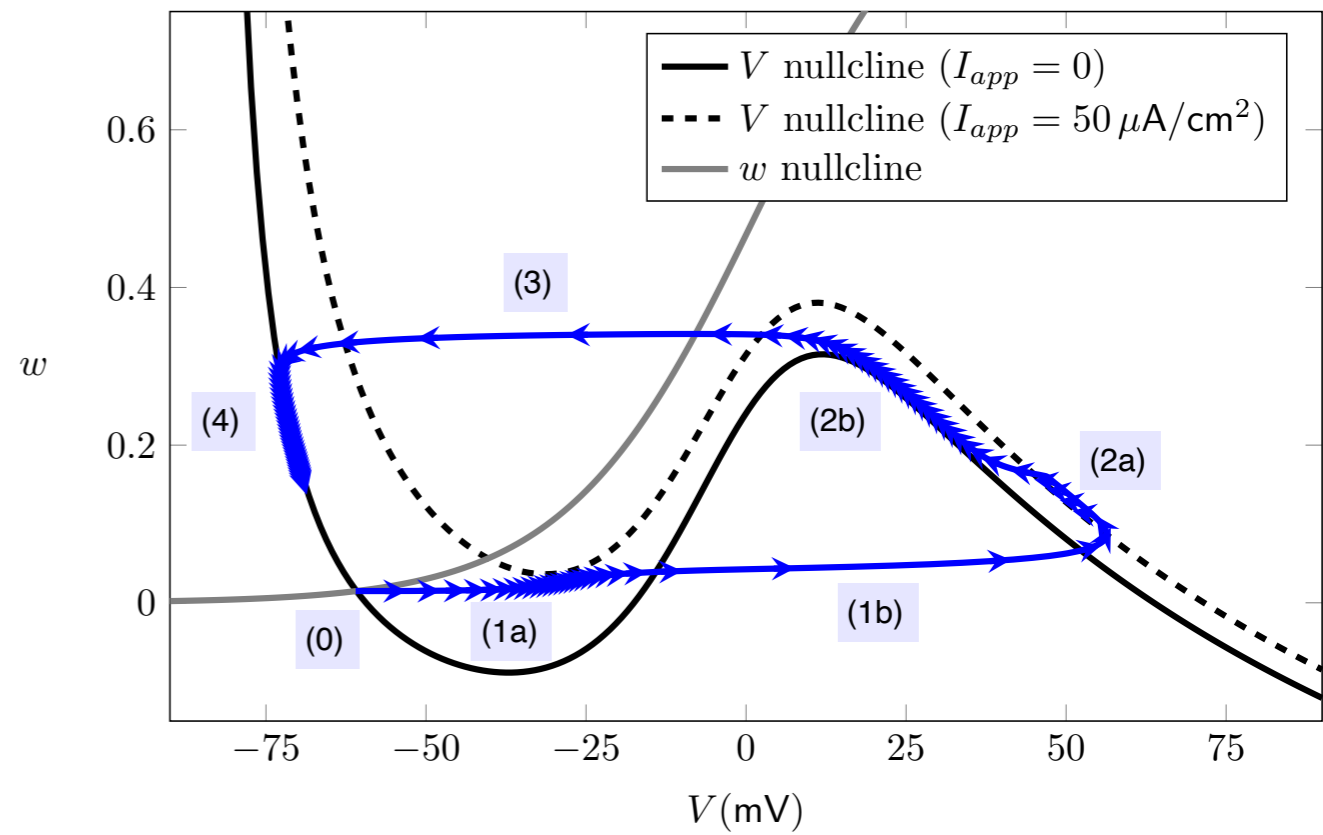
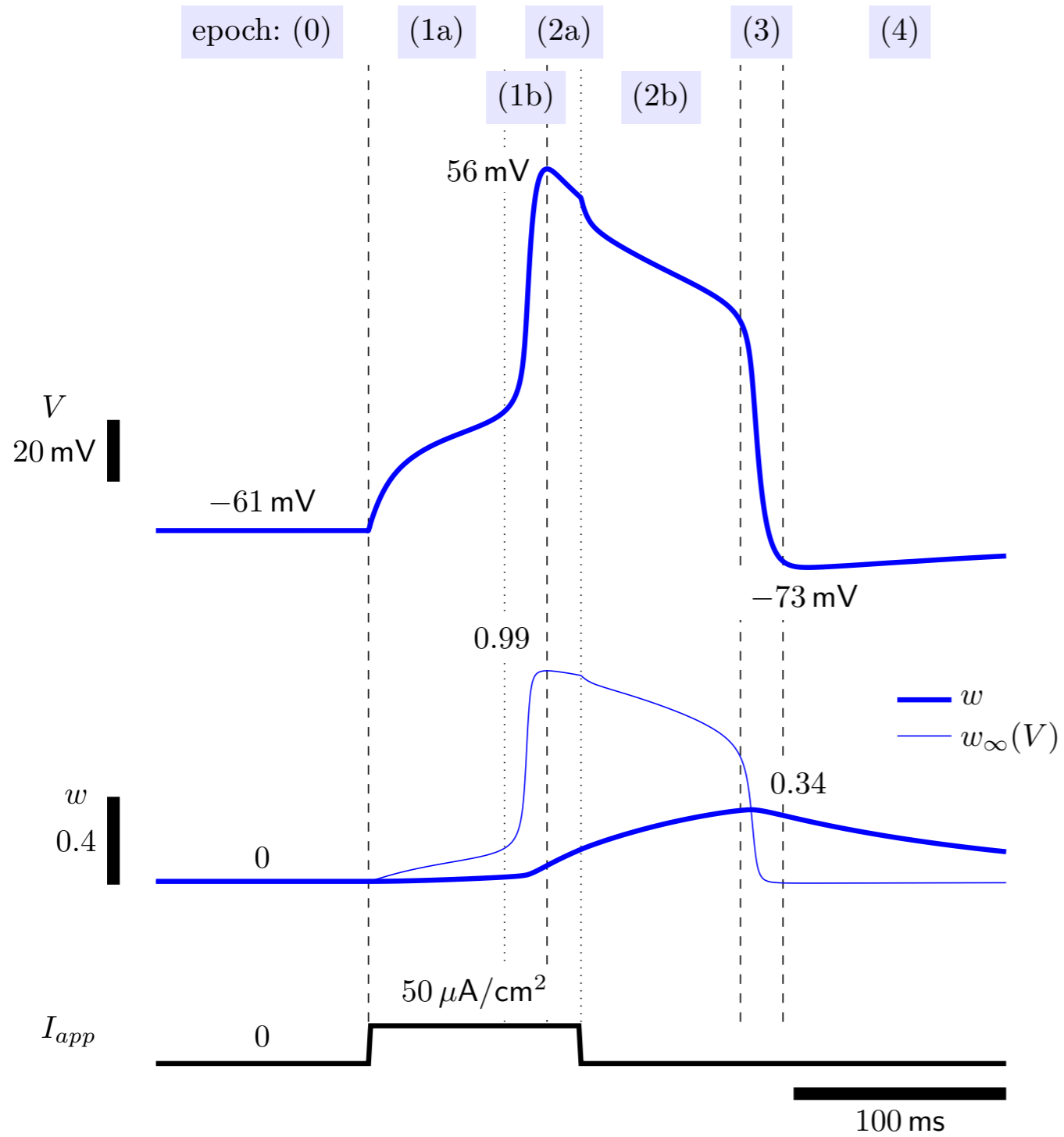

membrane oscillations

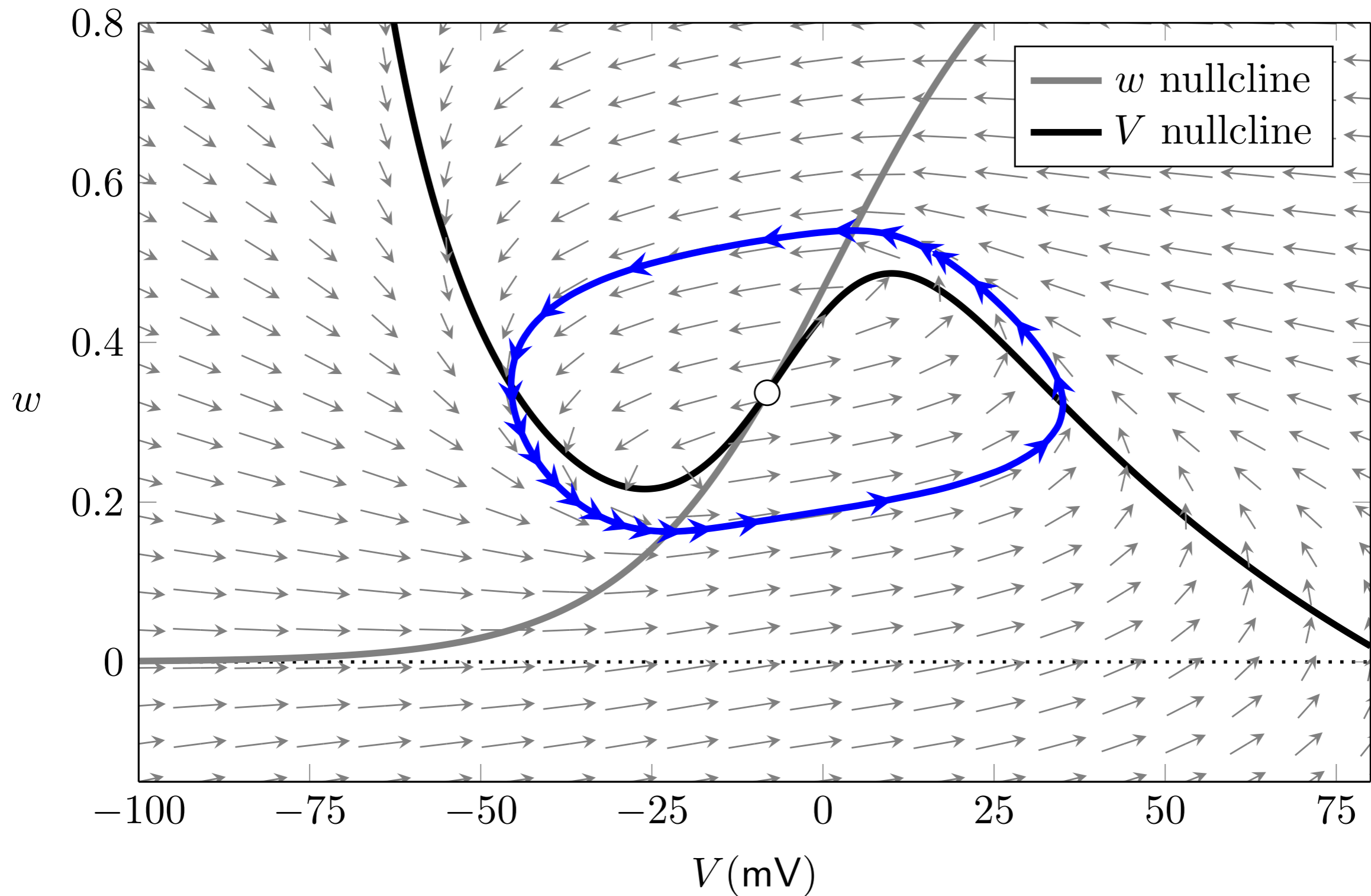

membrane oscillations when potassium channel gating is very slow (Φ is small so τ_w is large)

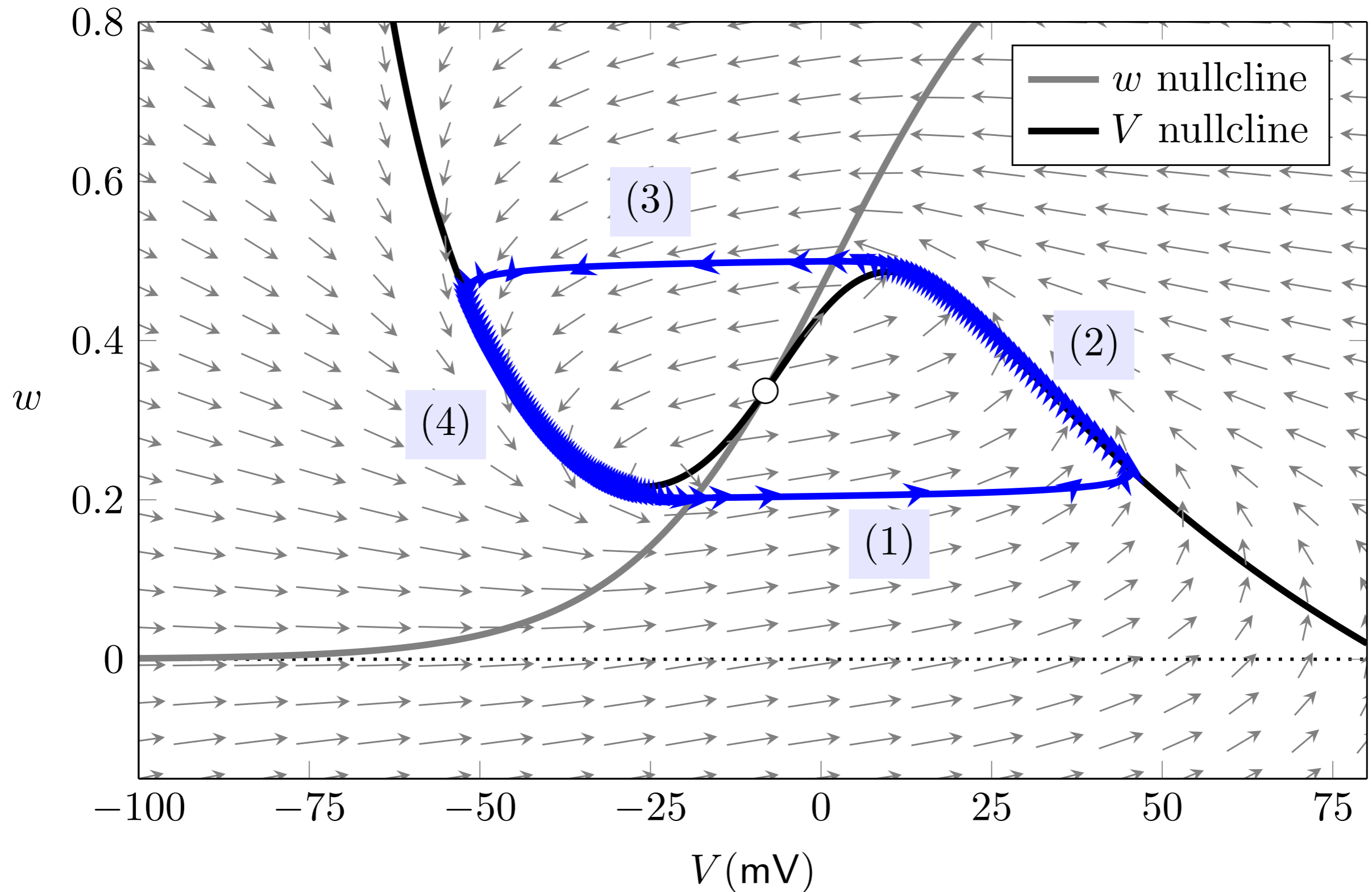

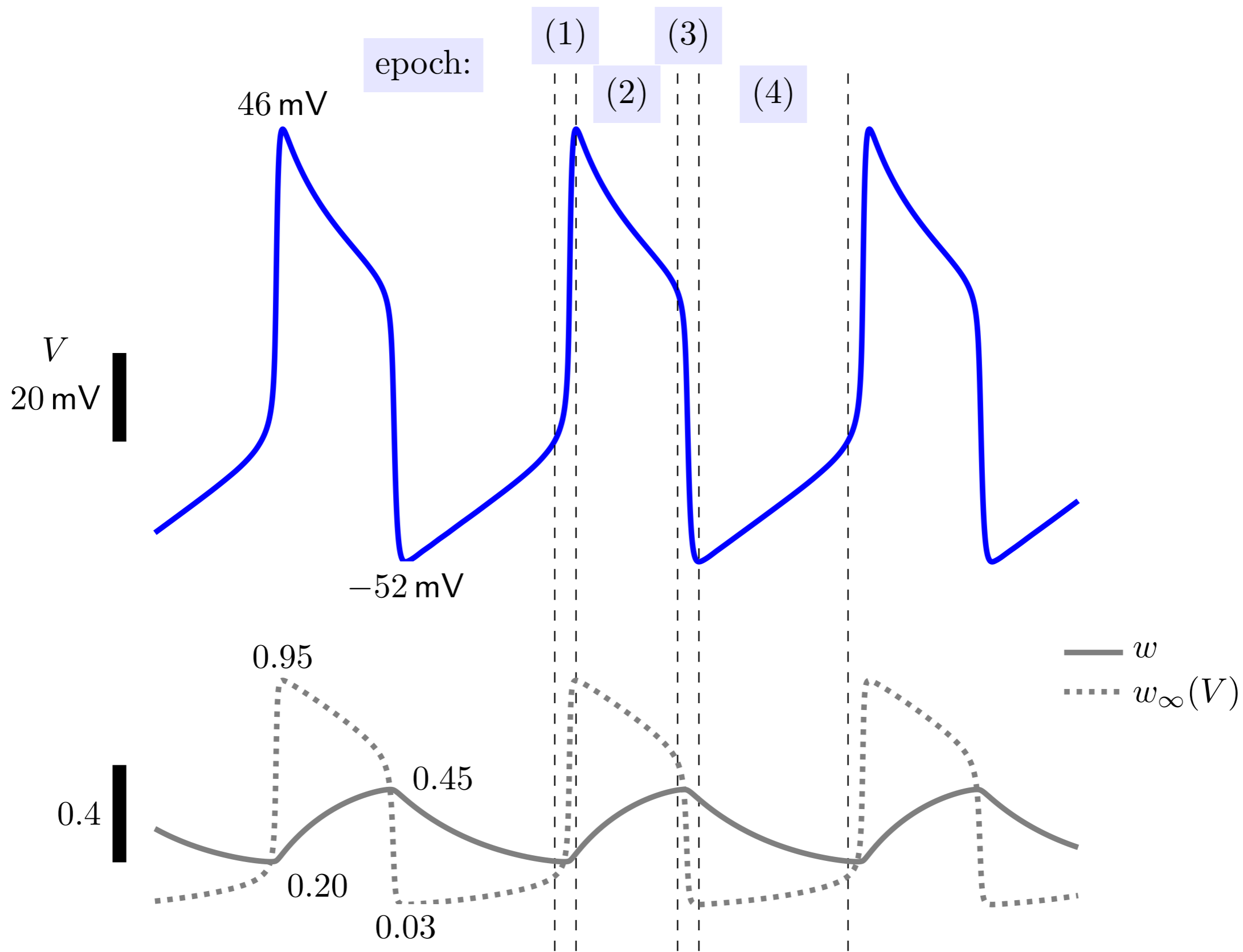

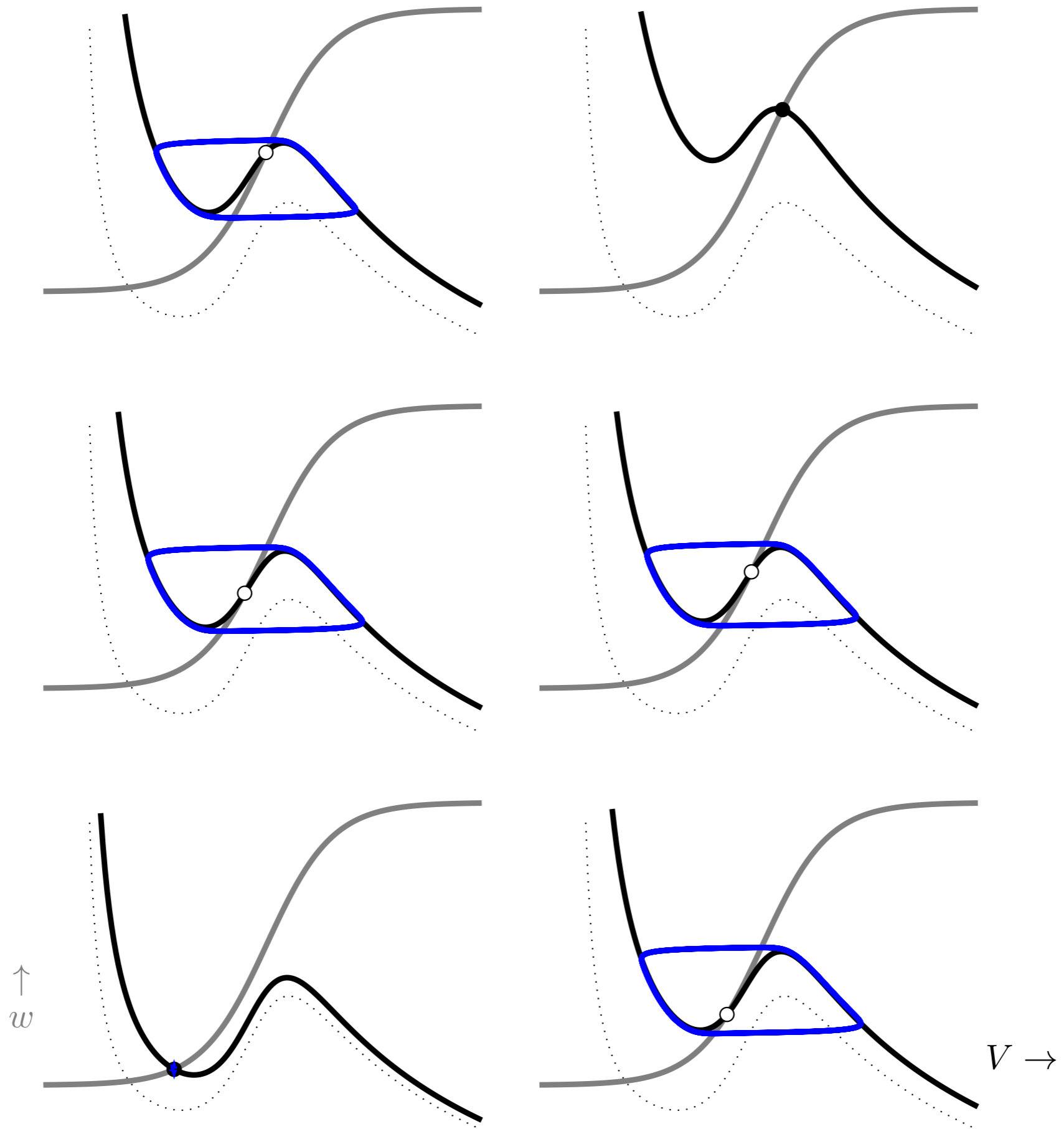

	type 1 response	type 2 response
oscillations (repetitive action potentials)	arbitrarily low frequency (continuous current-frequency relation)	nonzero minimum frequency (discontinuous current-frequency relation)
excitability (single action potential)	all-or-none action potential	graded action potential (can be effectively all-or-none)

As we discuss the Morris-Lecar model, the distinction between type 1 and 2 responses will be revisited and the table above is exactly what we will observe. However, it is possible for a Type 2 membrane to exhibit an extremely sharp graded threshold that is, for all practical purposes, indistinguishable from all-or-none.

In the context of the Hodgkin-Huxley model simulator you are currently using, you may observe a "mixture" of behaviors. Responses to current pulses give a current-frequency relation that has a discontinuity (Type 2-like), but the behavior of single action potentials is essentially all-or-none (Type 1-like). This mixed behavior can even occur in the Morris-Lecar model, if the potassium channel gating mechanism is very slow.

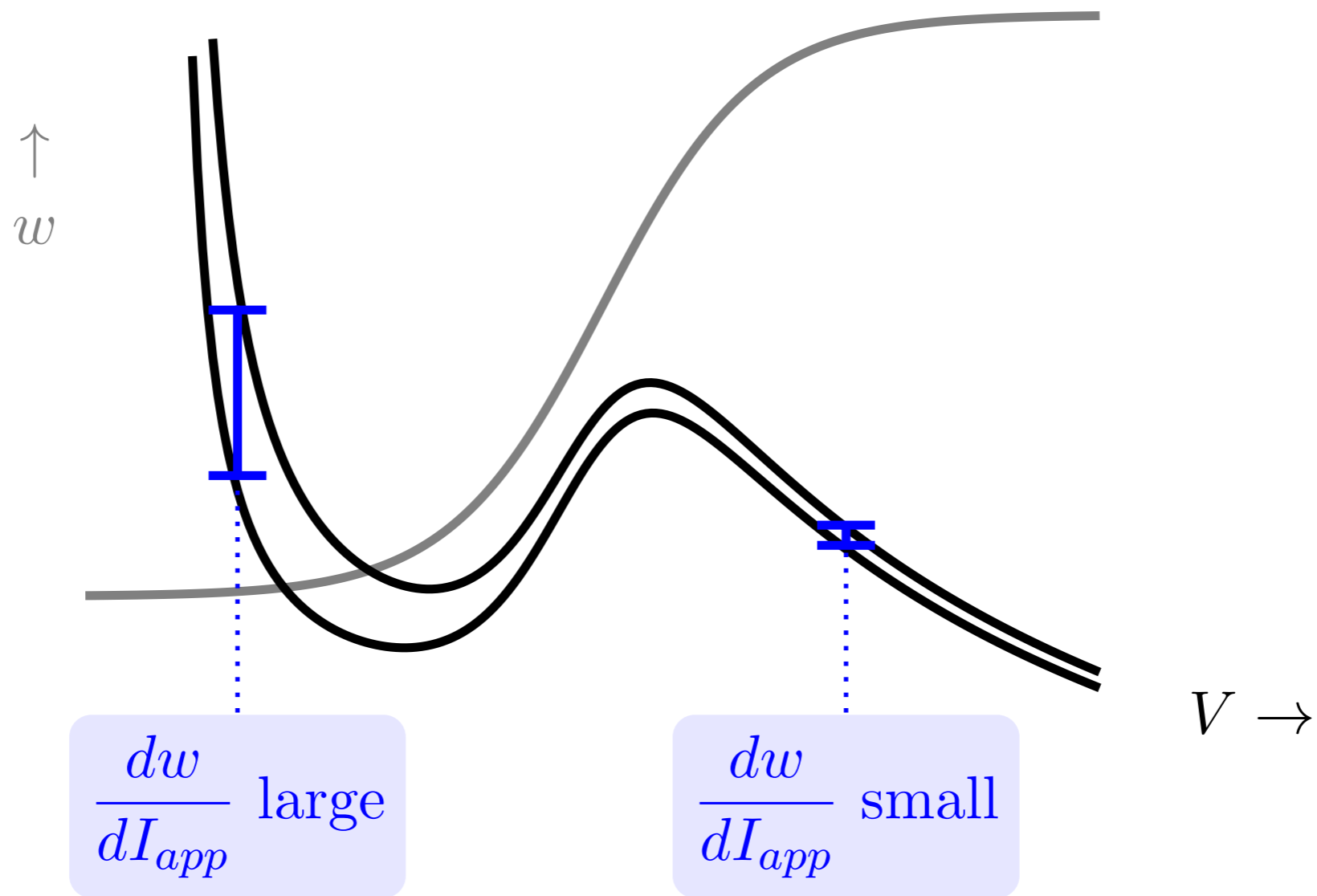

The voltage nullclines above use $I_{app} = 0$ and $50 \mu\text{A}/\text{cm}^2$ (black curves).